

**Service Instructions:**

Read these instructions and follow them for correct use. Since specific tools and knowledge are necessary for proper installation, it is recommended that the MTB crankset be installed by a qualified bicycle technician. These instructions and instructions for other FSA products are available for download at [www.fullspeedahead.com](http://www.fullspeedahead.com)

**Specification**

- FSA K-Force Light MTB CK-OS9200CCC
- FSA Afterburner CK-OS9150CCC
- FSA V-Drive CK-OS7060CCC
- Gravity Light CK-OS9160

**Tools**

- Circlip (Snap-ring) pliers
- FSA bearing installation tool # EE041
- FSA retaining nut tool # E0140
- 10mm allen tool
- Torque wrench
- Headset Press
- 1.5mm allen tool
- 36mm spanner wrench
- Bearing grease

**Components of FSA BB30 Crankset**

Follow the assembly order in the illustration:

- 0 BB Shell
- 1 Circlip (Snap-ring)
- 2 BB30 Bearing
- 3 Drive Side Bearing Shield
- 4 Non-Drive Side Bearing Shield (68mm only)
- 5 2.5mm spacer (68mm only)
- 6 Right Crank Arm and Spindle
- 7 Preload Nut
- 8 Preload Nut Set Screw
- 9 Preload Nut Circlip
- 10 Left Crank Arm
- 11 Washer (1.75mm)
- 12 BB30 Crank Bolt
- 13 Washer (3mm)
- 14 M25 Retaining Nut

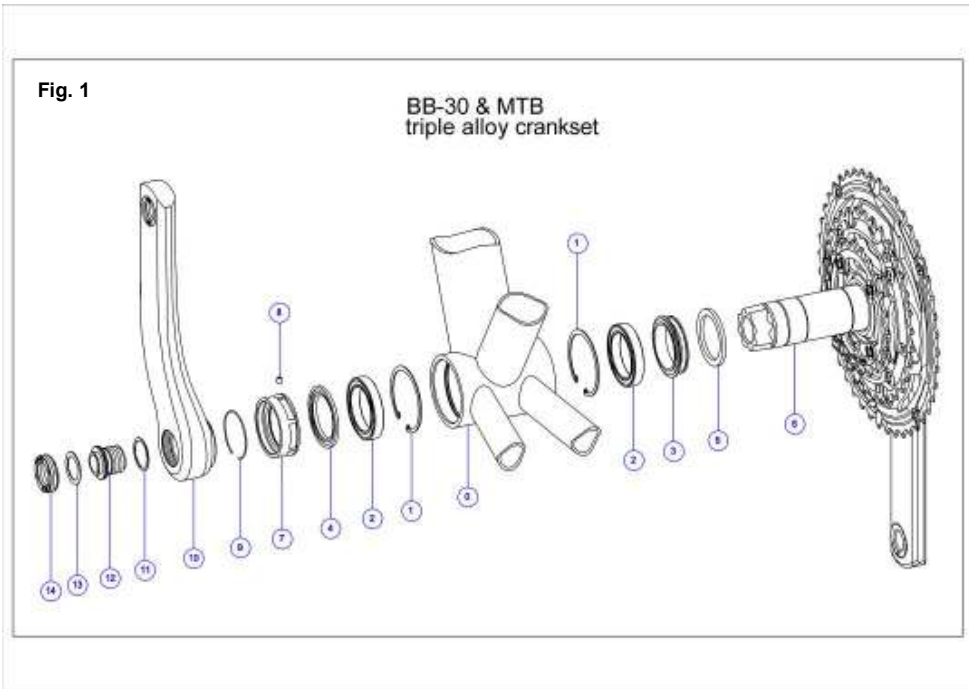

**Compatibility of FSA BB30 Crankset**

**68 and 73mm BB shells:**

FSA MTB cranksets are compatible with 68mm and 73mm BB shells..

1. For 68mm BB shells, use the included 2.5mm spacer (5) and Non-Drive Side Bearing Shield (4) as shown in Figure 2.
2. For 73mm BB shells, **do not** use 2.5mm spacer (5) and Non-Drive Side Bearing Shield (4) as shown in Figure 3.
3. See "Self Extracting Crank bolt and Preload setting" for Preload nut adjustment..

**Note: All spacers and bearing shields are supplied with the crankset. Do not use more spacers than included or it can result in damage to the crankset, accident, or injury.**

Fig. 2



Fig. 3

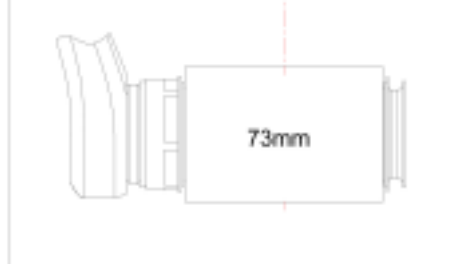

**Preparation:**

1. Ensure that Bottom Bracket (BB) shell (0) is clean and free of metal chips, dirt and excess paint.
2. Apply a thin layer of grease to the inside surface of the bottom bracket shell.

**Note: Do not face or machine BB shell. It is not necessary for BB30 system.**

**BB Shell Circlips:**

3. Apply a thin layer of grease to the BB Circlip groove.
4. Using a Circlip pliers, collapse circlip (1) and insert into machined circlip groove in BB shell as shown in Figure 4.
5. Ensure circlip is fully seated in groove.

**Warning: Wear eye protection. Circlips may have sharp edges and can cause serious eye injury by springing from BB or tool while installing.**

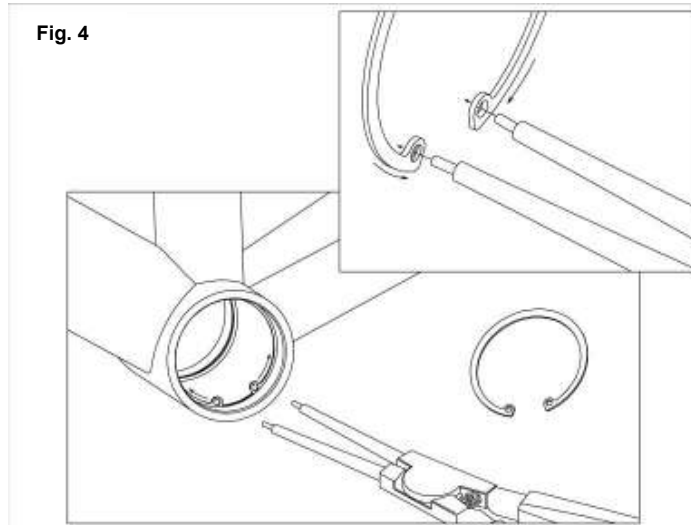

**Bearings:**

6. Apply a thin layer of grease to outer bearing surfaces (2).
7. Using FSA bearing installation tool # EE041 on a headset press, install one bearing by using tool and bearing arrangement shown in Figure 5. Press bearing into BB shell until it is butted against the circlip.
8. Install opposite side bearing by using tool and bearing arrangement shown in figure 6. Press bearing into BB shell until it is butted against the Circlip.
9. Place aluminum bearing shields (3) over bearings with machined grooves facing inward, toward the bearings.

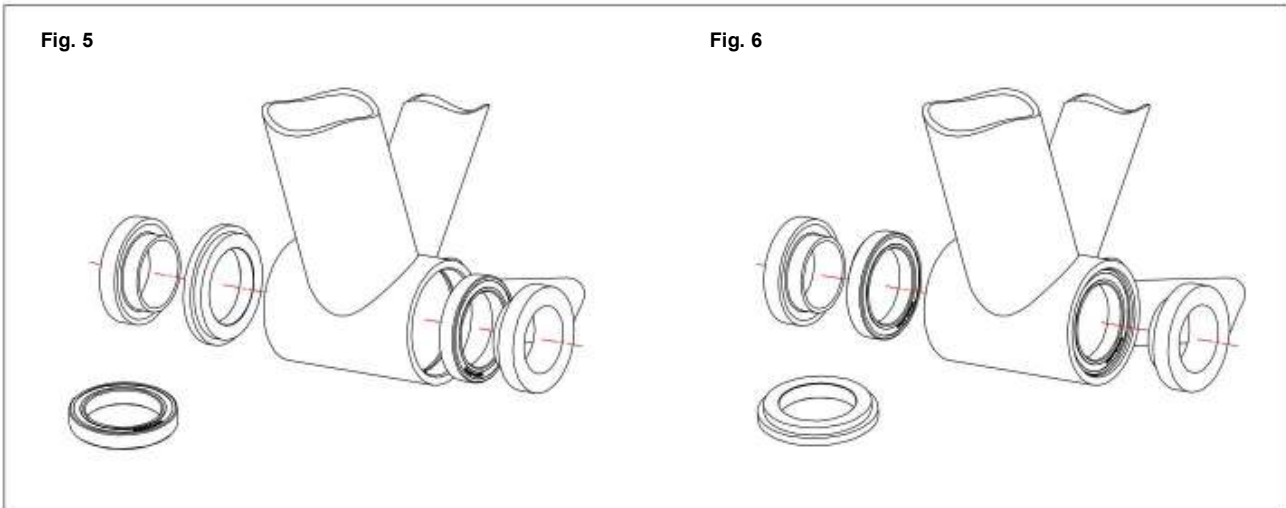

**Crankset and Preload Nut Preparation:**

10. Apply light layer of grease to spindle and completely insert the Right Crank Arm (6) through the BB30 Bearings (2).
11. Preload Nut is pre-installed from factory. Ensure preload nut (7) has a thin layer of grease on the threads and is completely screwed against the left arm (10) during installation. Preload Nut must also have set screw (8) and circlip (9) installed as shown in Figure 7.

**Note: Inspect Circlip opening is not aligned with set screw position. See Figure 8.**

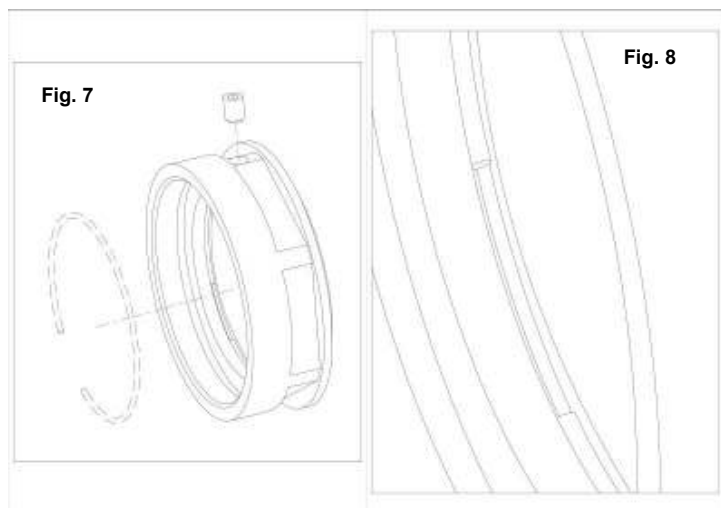

### Self Extracting Crank bolt and Preload Nut setting:

12. Self Extracting Crank bolt is pre-installed from factory. Crank bolt arrangement is as shown in Figure 9.
13. Thread Self Extracting Crank bolt into spindle using a torque wrench with 10mm allen. Tighten crank bolt to a torque of 39-49Nm.

**Note: Apply grease to the crank bolt threads.**

14. Adjust Preload Nut (part 7 in Figure 1) to 7-9Nm of torque with 36mm spanner wrench.
15. With 1.5mm allen, tighten Preload Nut Set Screw to secure Preload Nut.

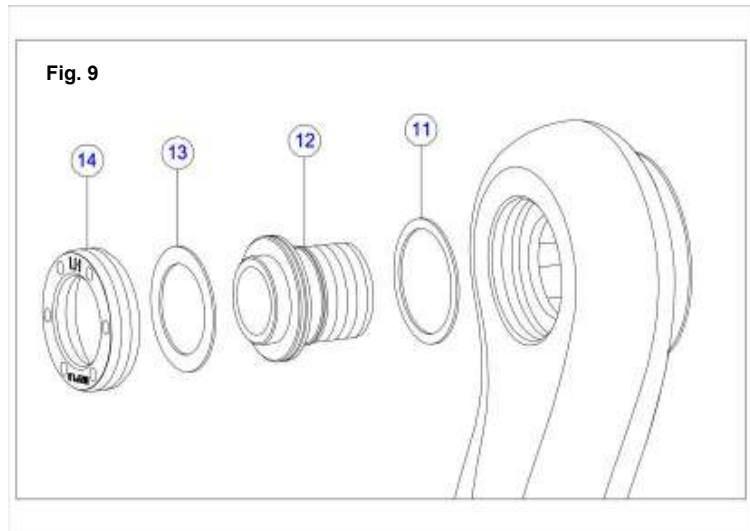

### Removal—FSA BB30 Crankset

#### Tools:

- FSA BB30 Removal tool #E0019
- 10mm allen tool
- Small hammer
- Punch or driver
- Circlip pliers (optional)

#### Preparation:

1. Using 10mm allen tool, extract left crank arm from the spindle with Self Extracting Crank bolt.
2. Remove crankarms and spindle from the BB.

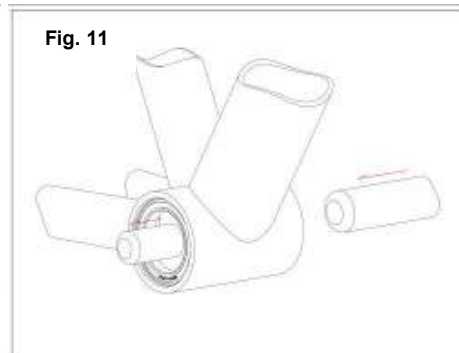
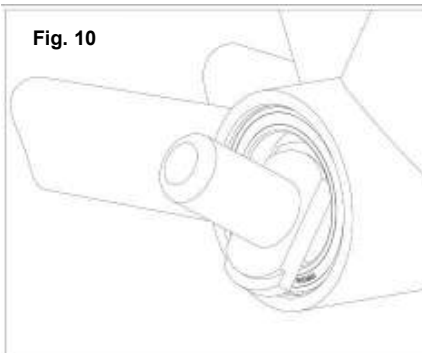

#### Removing Bearings:

3. Tilt FSA BB30 tool #E0019 inward and position on the inside face of the bearing as shown in figure 10.
4. Locate a driver on the opposite side of the tool. Using a small hammer, lightly tap the driver until bearing is removed from the BB shell. See Figure 11.
5. Repeat from other side.

**Note: Do not reinstall removed bearings. Always replace with new set.**

#### Removing Circlip:

6. Removal is reverse of installation. This is an unnecessary step for bearing replacement.

### Chaining Installation

#### Assembly:

1. With the FSA Logos and printed surface facing out, position the larger chainring so that the chain drop prevention pin is located behind the crank arm. For cranks with bash guards instead of outer chainrings, assemble with FSA Logos facing out.
2. With the FSA Logos and printed surface facing out, position the inner chainring so that the alignment guide is located behind the crank arm. Use the same installation procedure for the third chainring on a triple crankset.
3. Apply grease to the chainring bolt threads and surfaces where they contact the crank arm and chainrings. Fasten the chainrings to the crankarm using the chainring bolts at a torque of 9-12 Nm.

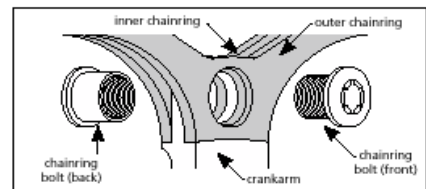
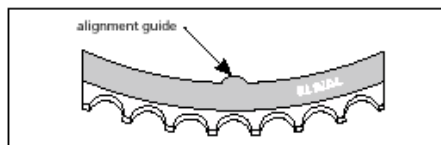
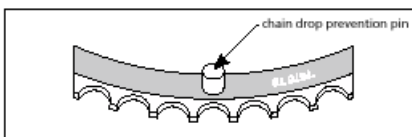

### Pedal Installation

#### Assembly:

1. Grease pedal threads.
2. Torque pedals to 29-34 Nm.

**Warning: FSA does not recommend the use of pedal extenders.**

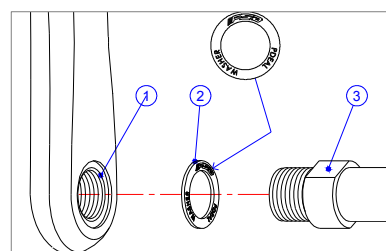

## Maintenance

---

It is the product user's responsibility to examine the product on a regular basis to determine the need for service or replacement. Cyclists should inspect their bicycle and parts on a regular basis in order to detect damage that may have occurred from normal use and abuse. Check all parts for damage and wear before every use. Should any problems or concerns arise, discontinue riding the bicycle and have it inspected by a qualified bicycle technician.

**WARNING: In the event of a bicycle accident, all parts should be thoroughly examined by a qualified bicycle mechanic, and any damaged parts replaced.**

All damaged parts should be repaired or replaced by a qualified bicycle mechanic before the bicycle is used again. Continuing to use damaged parts may lead to loss of control of the bicycle and cause injury or death.

## Warranty

---

### FSA Warranty 2008

Full Speed Ahead (FSA) warrants all FSA, Gravity, VisionTech, and RPM products to be free from defects in materials or workmanship for a period of two years after original purchase unless otherwise stated below. The warranty is non-transferable and valid to the original purchaser of the product only. If your product included a written policy in the packaging that differs from the warranty policy posted at [www.fullspeedahead.com](http://www.fullspeedahead.com), the policy at [www.fullspeedahead.com](http://www.fullspeedahead.com) is to be considered most current and in effect.

### Exceptions to the 2 year Warranty

**Headsets:** Orbit Xtreme and Orbit Xtreme Pro headset models are guaranteed against defects in materials and workmanship for ten years from date of purchase.

**Bearings:** All bearings; headset, bottom bracket, wheel, derailleur in both steel and ceramic carry a warranty period of one year from date of purchase except in European countries which have two year warranty. **Note:** Bearings that fail due to contamination, misuse, improper, or lack of maintenance are not covered under warranty even if failure occurs within one year from date of purchase.

**Handlebars:** All Full Speed Ahead alloy and carbon fiber road and mountain bike handlebars are guaranteed against defects in materials and workmanship for two years from date of purchase. This warranty does not cover bent handlebars or damage due to use of bar ends or clip-on bars. Handlebars may have an effective usable life less than two years depending on amount of use, type of use and other conditions. Cyclists should inspect their handlebars on a regular basis in order to detect damage that may have occurred from normal use or abuse.

**Seatposts:** All Full Speed Ahead alloy and carbon fiber seatposts are guaranteed against defects in materials and workmanship for two years from date of purchase. Carbon fiber seatposts that have been, cracked, damaged or broken in the area where the frames seatpost clamp tightens the seatpost are not covered under this warranty.

### Explanation of Warranty:

All FSA products have an intended purpose, if the product is used outside of that purpose, product will not be warranted and FSA cannot be held responsible for any damage that may occur due to misuse. It is the product users' responsibility to examine the product on a regular basis to determine the need for service or replacement. Not covered under this warranty are the following:

- FSA products that have been modified, neglected or poorly maintained.
- FSA products that are purchased used, not in original packaging, or from an authorized dealer or distributor.
- FSA products that have been damaged in shipping.
- FSA products that have been used in competition, stunt riding, or for commercial use. This includes bending or breaking components due to the use and abuse of components used for dirt jumping, trials, street or park, downhill and free-riding.
- Damage to products improperly installed or repaired as recommended by FSA.
- Stripped pedal threads on cranks are not covered under warranty.
- Damage from causes other than defects in materials and workmanship such as a user's lack of skill, competence or experience.
- The finish or aesthetics of the product are not covered under this warranty.
- Any labor costs associated with the removal, replacement or reassembly of the product.
- Normal wear to the product. Components may have symptoms of wear in less than two years depending on amount of use, type of use and other conditions. This includes products that have reached the end of their normal life expectancy.
- Any FSA, Gravity, VisionTech, and RPM products purchased through unauthorized dealers (eBay or otherwise) carry NO WARRANTY and are sold as-is.

### To Obtain Warranty Service:

Eligibility for warranty is determined by FSA warranty/tech personnel. Proof of purchase is **required** to validate warranty period. Please keep your proof of purchase. Items returned for warranty determination without proof of purchase will be returned at customer's expense.

It is necessary to return the product to FSA for inspection before any replacement under warranty can be deemed. Only FSA or an Authorized FSA Warranty Center may determine if a product is warrantable. If the product is not covered under warranty, all replacement, repair, and shipping costs are responsibility of the customer. At no time may any retailer or distributor make representations of warranty for FSA products without express written permission from FSA. Should a retailer or distributor replace product before consulting FSA, it is at the sole discretion of the retailer or distributor and may not be reimbursed by FSA.

Before returning product to FSA, please follow the instructions below to receive a return authorization (RA) number.

**Consumers:** Claims for warranty must be made through the retail location where the product, or bicycle with FSA original equipment (OEM), was purchased. The retail location should contact FSA or the closest Authorized FSA warranty center to obtain a RA number. Proof of purchase is **required** to validate warranty period. Please keep your proof of purchase.

**Retailers:** Contact FSA or an Authorized FSA Warranty Center to obtain an RA (return authorization) number. Send the FSA product with RA number clearly printed on the box; along with a copy of the purchase receipt, or other satisfactory proof of purchase to Full Speed Ahead in the United States. If you are outside of the United States, contact the Authorized FSA Warranty Center closest to your country of residence for warranty determination. A list of Authorized FSA warranty centers is posted at [www.fullspeedahead.com](http://www.fullspeedahead.com).

Any postage, insurance, or shipping costs incurred in sending your product for service are the customer's responsibility. Once received by FSA or Authorized FSA Warranty Center, the product will be inspected to determine if it is covered by the FSA warranty policy. After receipt and inspection by FSA warranty personnel and deemed warrantable, FSA will perform the necessary repair or replacement. Should there be any cost to the customer, they will be notified prior to any repair being performed.

In the case where the product is not covered under warranty, FSA will repair the product at customer's expense or offers replacement under the "Crash Replacement Policy". This policy covers a 2 year period following the purchase date of the product. The crash replacement policy offers replacement of damaged, non-warrantable, non-repairable product at a reduced price. If the customer declines the crash replacement offer or repair service, the customer will need to cover the cost of returning the product. If the customer declines service or replacement offer and the product is deemed unsafe for use, the product will be returned in an unusable condition to guarantee rider safety. If FSA does not receive an acceptance or decline of service from customer after 90 days from the date offer is made to customer, then the product becomes the property of FSA and may be destroyed.

### Limits of Warranty

At its sole discretion, FSA agrees to repair or replace products deemed by FSA to be defective as indicated below. FSA reserves the right to replace product with like replacements that may have graphics or finishing different from the original part. If a part defect arises and a valid claim is received within the Warranty Period, at its option, FSA will either (1) repair the defect at no charge, or (2) exchange the product with a product that is new or which is at least functionally equivalent to the original product. FSA may request that you replace defective parts with new or refurbished user-installable parts that FSA provides in fulfillment of its warranty obligation. A replacement product or part, including a user-installable part that has been installed in accordance with instructions provided by FSA, assumes the remaining warranty of the original product or ninety (90) days from the date of replacement or repair, whichever provides longer coverage for you. When a product or part is exchanged, any replacement item becomes property of the customer and the item replaced becomes property of FSA.

To the extent permitted by law, this warranty and remedies set forth above are exclusive and in lieu of all other warranties, remedies and conditions, whether oral or written, statutory, express or implied. As permitted by applicable law, FSA specifically disclaims any and all statutory or implied warranties, including, without limitation, warranties of merchantability, fitness for a particular purpose and warranties against hidden or latent defects. If FSA cannot lawfully disclaim statutory or implied warranties then to the extent permitted by law, all such warranties shall be limited in duration to the duration of this express warranty and to repair or replacement service as determined by FSA in its sole discretion. No FSA reseller, agent, or employee is authorized to make any modification, extension, or addition to this warranty.

Except as provided in this warranty and to the extent permitted by law, FSA is not responsible for direct, special, incidental or consequential damages resulting from any breach of warranty or condition, or under any other legal theory, including but not limited to loss of use; loss of revenue; loss of actual or anticipated profits (including loss of profits on contracts); loss of the use of money; loss of anticipated savings; loss of business; loss of opportunity; loss of goodwill; loss of reputation; loss of, or any indirect or consequential loss.

### Contact Information

---

Full Speed Ahead – USA, 12810 NE 178th St. #102, Woodinville, WA 98072, U.S.A.  
[www.fullspeedahead.com](http://www.fullspeedahead.com) 1-425-488-8653

Full Speed Ahead – Europe, Via Del Lavoro 56, 20040 Busnago, Milano Italy  
[www.fullspeedahead.com](http://www.fullspeedahead.com) 39 039 688 5625