

THIS KIT IS REQUIRED TO CONVERT "83MM BB SHELL" (LONG 163MM AXLE) VERSIONS OF RACE FACE DIABOLUS OR EVOLVE DH X-TYPE CRANKSETS TO FIT FRAMES WITH CONVENTIONAL 68MM OR 73MM WIDE BOTTOM BRACKET SHELLS.

Q: WHY WOULD YOU WANT THIS CONVERSION KIT?

A: IF YOUR FRAME HAS A 68MM OR 73MM WIDE BB SHELL AND YOU REQUIRE A WIDER BB AXLE THAN THE CONVENTIONAL 68 / 73MM RACE FACE X-TYPE DH ASSEMBLY (148MM AXLE) PROVIDES* BECAUSE YOU HAVE ONE OR MORE OF THE FOLLOWING REQUIREMENTS:

- YOUR FRAME HAS 150MM WIDE REAR DROPOUT / HUB AXLE "Over Locknut Dimension" (O.L.D.) SPACING.
- YOU NEED TO MOVE THE CRANKSET OUTBOARD TO CREATE OPTIMAL CHAINLINE FOR USE WITH A SINGLE RING / CHAINGUIDE SYSTEM.
- YOU NEED TO MOVE ONE OR BOTH CRANK ARMS OUTBOARD TO CREATE MORE CRANK ARM-TO-FRAME OR CHAINRING-TO-FRAME CLEARANCE.
- YOU NEED TO MOVE THE CRANKSET OUTBOARD TO ACHIEVE A 57-58MM CHAINLINE REQUIRED FOR FRONT SHIFTING WITH SHIMANO'S NEW 83MM SHELL / 150MM O.L.D. SAINT DRIVETRAIN COMPONENTS. **

* THE ASSEMBLY DEPICTED ON THIS SHEET APPROXIMATES USE OF A 128MM ISIS DRIVE DH BB WITH A NORTH SHORE DH ISIS CRANK ON A CONVENTIONAL 68 OR 73MM BB SHELL FRAME.
 ** CONSULT DERAILLEUR MANUFACTURER'S SPECIFICATIONS FOR COMPATIBLE FRONT DERAILLEUR MODELS DESIGNED FOR USE WITH 57-58MM CHAINLINE / 150MM O.L.D. FRAMES.

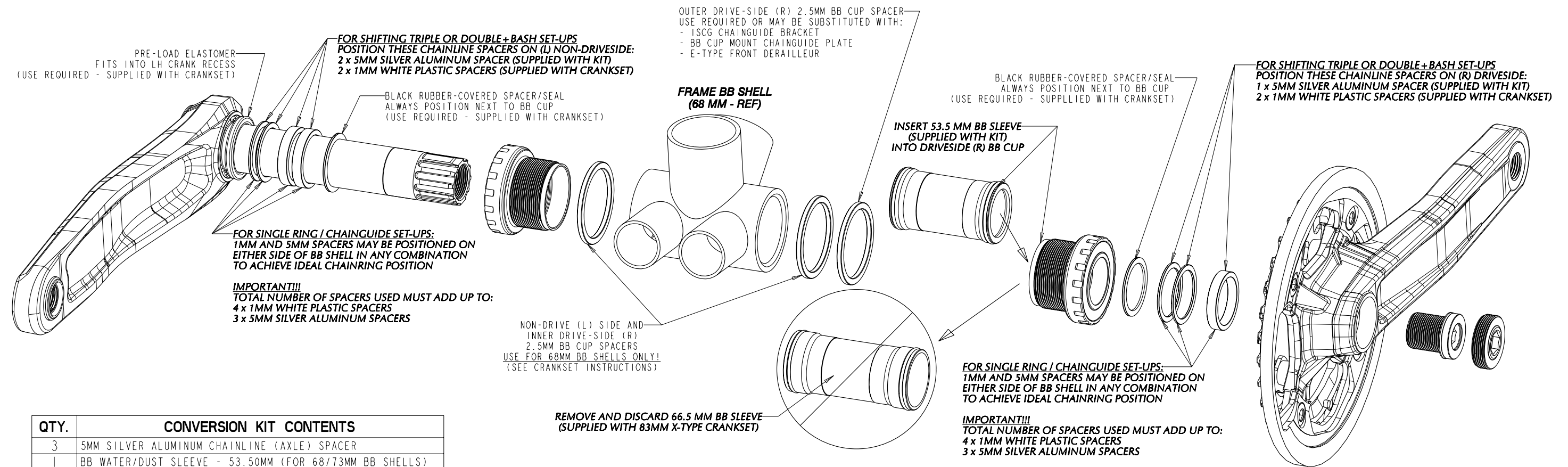

QTY.	CONVERSION KIT CONTENTS
3	5MM SILVER ALUMINUM CHAINLINE (AXLE) SPACER
1	BB WATER/DUST SLEEVE - 53.50MM (FOR 68/73MM BB SHELLS)

ATTENTION!!! WARNING!!! IMPORTANT NOTE:

THIS SHEET IS ONLY INTENDED AS A SUPPLEMENT TO THE INSTALLATION INSTRUCTIONS PROVIDED WITH YOUR RACE FACE X-TYPE DH 83MM CRANKSET.

PLEASE CAREFULLY READ AND FOLLOW ALL INSTRUCTIONS TO ENSURE TOP PERFORMANCE AND LONG-TERM LIFE OF YOUR X-TYPE CRANK AND BOTTOM BRACKET SET.

THE INFORMATION CONTAINED HEREIN IS PROPRIETARY AND IS NOT TO BE RELEASED WITHOUT PRIOR WRITTEN APPROVAL

RACE FACE #100-100 BRAID ST, NEW WESTMINSTER, BRITISH COLUMBIA, CANADA V3L 3P4
 TEL (604) 527-9996 / FAX (604) 527-9959

TOLERANCES (unless otherwise specified)	DRN B. JOHNSON	DATE JAN. 31/05	TITLE: X-TYPE DH 83MM ASSY TO 68/73MM BB SHELL CHAINLINE SPACER AND BB SLEEVE CONVERSION KIT	
	DES B. JOHNSON	DATE JAN. 31/05	DWG FILENAME: X-TYPE-DH-83-TO-68-OR-73-RETRO	PART NO: 83 TO 68/73 CONVERSION KIT
	CKD	DATE	SIZE B	SCALE: 3:20 UN
	MFG APP	DATE	DIMENSION UNITS: MM (unless noted)	SHEET OF