

REV	DATE	CLASS	REVISION RECORD	DR	CK
A	23DEC05	M	ECN 17149 RELEASE FOR MY07	JJB	BMB
B	11JAN06	D	ECN 17296: ADD NOTES 8, 9, 10. CHANGE DWG LAYOUT, CHANGE NOTE 6. UPDATE DIM FORMAT FOR TIRE CLEARANCE AND TOP CAP CLEARANCE ENVELOPES. DELETE ISO VIEW.	MJW	DG
C	02MAY06	D	ECN 18926 CHANGE: Ø698 WAS Ø713.8(G9), UPDATE VIEW	JJB	CM

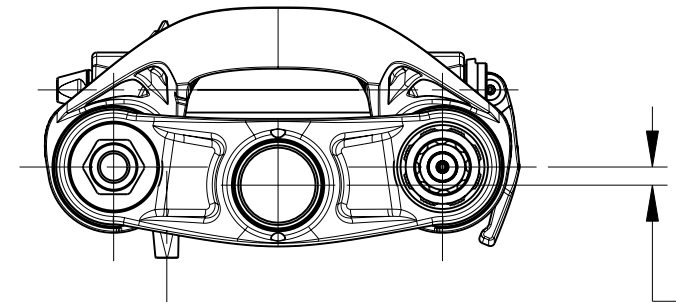

1-1/8 & 1.5 STEER TUBE OPTIONS AVAILABLE

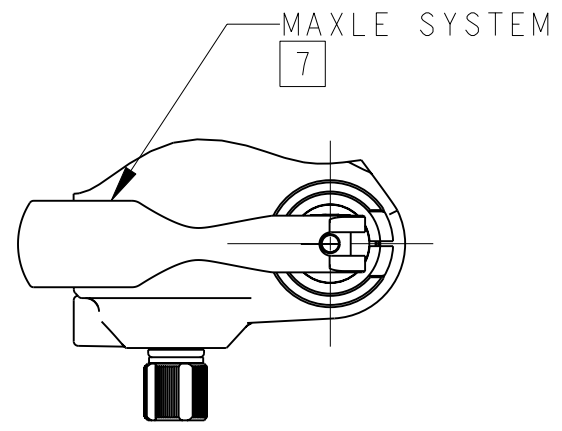
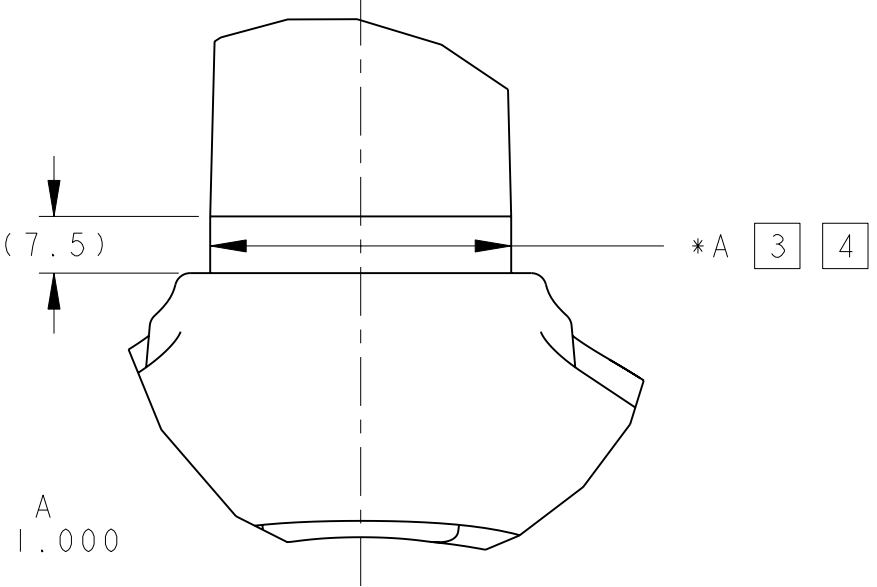
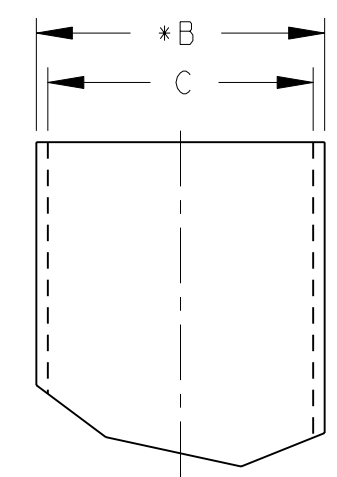

STEER TUBE	*A [3] [4]	*B	C
1-1/8 ALUM	30.040+0.050/-0.025	28.58±0.07	24.45±0.15
1.5 ALUM	39.820+0.050/-0.025	38.14±0.07	34.95±0.15

- NOTES:
- SRAM RESERVES THE RIGHT TO CHANGE SPECIFICATIONS WITHOUT PRIOR NOTICE.
  - REFERENCE DIMENSIONS NOTED WITH "( )" ARE FOR CUSTOMER DESIGN INFORMATION ONLY
  - CROWN RACE Ø'S MEASURED AS AVERAGE OF 3 DIAMETRIC POINTS MINIMUM
  - HEADSET CUP ID MUST BE GREATER THAN STEER TUBE OD + 0.3MM
  - 110 X 20MM THUR AXLE HUB ONLY WITH Ø25MM MAX OUTER SHOULDER AND Ø20.05 MIN INNER DIAMETER BORE
  - IMPORTANT: CUSTOMER IS RESPONSIBLE FOR ENSURING MINIMUM TIRE CLEARANCE. DO NOT EXCEED MAXIMUM TIRE ENVELOPE INDICATED ON THIS DRAWING
  - IMPORTANT: CUSTOMER IS RESPONSIBLE FOR ENSURING THAT ROCKSHOX MAXLE SYSTEM IS USED PER SRAM'S OPERATING INSTRUCTIONS (SEE USER MANUAL)
  - POST TYPE BRAKE CALIPER MOUNT, DIRECT FOR 203MM ROTOR DIAMETER. MAX ROTOR DIA = 215MM
  - FORK / FRAME CLEARANCE (WORST CASE)
  - 3D FILES: US-4012-882-000.IGS, US-4012-882-000.STP AVAILABLE UPON REQUEST

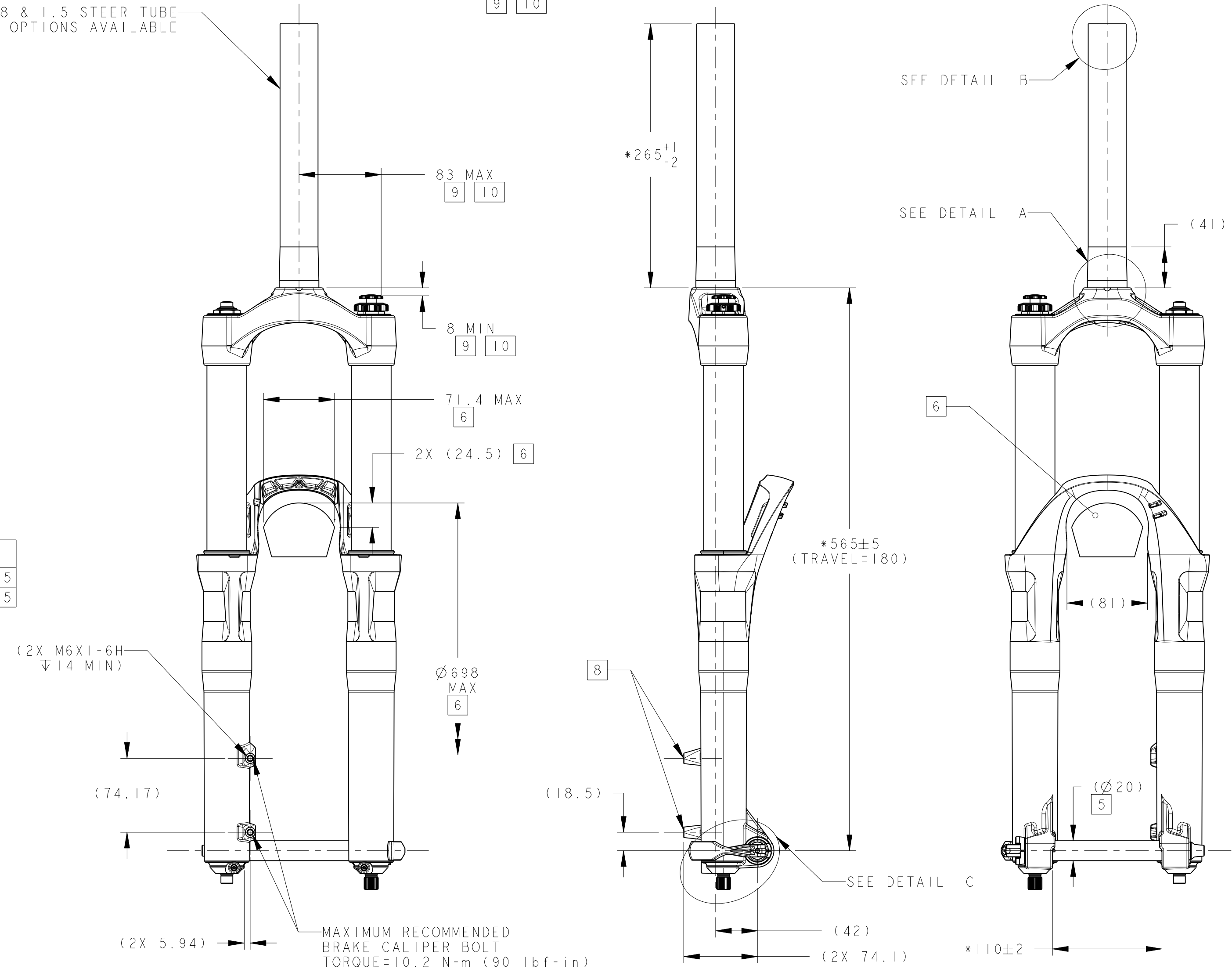

SRAM Corporation  
Global Headquarters  
1333 North Kingsbury  
Chicago, IL 60622  
USA 312-664-8800  
REV B

GEOMETRIC DIMENSIONING AND TOLERANCING TO BE INTERPRETED PER ANSI Y14.5M 1994

ALL DIMENSIONS ARE mm

THIRD ANGLE PROJECTION

UNTOLERANCED LENGTH DIMENSIONS (mm)	TOLERANCE
From 0.5 up to 6	±0.1
over 6 up to 25	±0.2
over 30 up to 120	±0.3
over 120 up to 400	±0.5
UNTOLERANCED ANGLE DIMENSIONS	±5°

DO NOT SCALE DRAWING

DRAWN BY: J. BALTES

APPROVAL: M. BIBB

CONFIDENTIAL - THIS DRAWING CONTAINS INFORMATION THAT IS PROPRIETARY TO SRAM CORPORATION AND MAY NOT BE DISCLOSED WITHOUT PERMISSION.

TITLE: ROCKSHOX USER SPECIFICATION, MY07 TOTEM

SCALE: A2 DATE: 23DEC05 DRAWING NUMBER: US-4012-882-000 REV: C