

General Safety Information

WARNING

"Maintenance interval depends on the usage and riding circumstances. Clean regularly the chain with an appropriate chaincleaner. Never use alkali based or acid based solvents such as rust cleaners. If those solvent be used chain might break and cause serious injury."

"In order to obtain good gear shifting performance, this chain has a forward side and a reverse side, and the sides are marked so that the chain will face the correct way when installed. The proper design performance will be obtained when the chain is installed so that it faces the correct way. If it is installed so that it faces the opposite way, the chain may come off and the bicycle may fall over and serious injury may occur as a result."

- Use the reinforced connecting pin only for connecting the narrow type of chain.
- If connecting pins other than reinforced connecting pins are used, or if a reinforced connecting pin or tool which is not suitable for the type of chain is used, sufficient connection force may not be obtained, which could cause the chain to break or fall off.
- If it is necessary to adjust the length of the chain due to a change in the number of sprocket teeth, make the cut at some other place than the place where the chain has been joined using a reinforced connecting pin. The chain will be damaged if it is cut at a place where it has been joined with a reinforced connecting pin.
- Be careful not to let the cuffs of your clothes get caught in the chain while riding, otherwise you may fall off the bicycle.
- Check that the tension of the chain is correct and that the chain is not damaged. If the tension is too weak or the chain is damaged, the chain should be replaced. If this is not done, the chain may break and cause serious injury.
- The two left crank arm mounting bolts should be tightened alternately in stages rather than each bolt being fully tightened all at once. Use a torque wrench to check that the final tightening torques are within the range of 12 - 14 N·m. Furthermore, after riding approximately 100 km (60 miles), use a torque wrench to re-check the tightening torques. It is also important to periodically check the tightening torques. If the tightening torques are too weak or if the mounting bolts are not tightened alternately in stages, the left crank arm may come off and the bicycle may fall over, and serious injury may occur as a result.
- Check that there are no cracks in the crank arms before riding the bicycle. If there are any cracks, the crank arm may break and you may fall off the bicycle.
- If the inner cover is not installed correctly, the axle may rust and become damaged, and the bicycle may fall over and serious injury may occur as a result.
- Obtain and read the service instructions carefully prior to installing the parts. Loose, worn or damaged parts may cause the bicycle to fall over and serious injury may occur as a result. We strongly recommend only using genuine Shimano replacement parts.
- Obtain and read the service instructions carefully prior to installing the parts. If adjustments are not carried out correctly, the chain may come off and this may cause you to fall off the bicycle which could result in serious injury.
- Read these Technical Service Instructions carefully, and keep them in a safe place for later reference.

Chain	Reinforced connecting pin	Chain tool
10-speed super narrow chain for MTB	with groove (3)	TL-CN32 TL-CN23 TL-CN27
	with groove (2)	

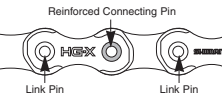

CAUTION

- If the chain is on the smallest or intermediate chaining, there is the danger of injury from the tips of the teeth on the largest chaining.

- Note**
- In addition, if pedaling performance does not feel normal, check this once more.
 - Before riding the bicycle, check that there is no play or looseness in the connection. Also, be sure to retighten the crank arms and pedals at periodic intervals.
 - If a squeaking noise is heard coming from the bottom bracket axle and the left crank arm connector, apply grease to the connector and then tighten it to the specified torque.
 - Use a neutral detergent to clean the crank arm and the bottom bracket. Using alkaline or acidic detergents may cause discoloration.
 - Do not wash the bottom bracket with high-pressure jets of water.
 - If you feel any looseness in the bearings, the bottom bracket should be replaced.
 - If gear shifting operations do not feel smooth, wash the derailleur and lubricate all moving parts.
 - If the amount of looseness in the links is so great that adjustment is not possible, you should replace the derailleur.
 - You should periodically wash the chainrings in a neutral detergent and then lubricate them again. In addition, cleaning the chain with neutral detergent and lubricating it can be an effective way of extending the useful life of the chainrings and the chain.
 - If the chain keeps coming off the chainrings during use, replace the chainrings and the chain.
 - When the chain is in the position shown in the illustration, the chain may contact the front chainrings or front derailleur and generate noise. If the noise is a problem, shift the chain onto the next-larger rear sprocket or the one after.
 - For frames with suspension, the chain stay angle will vary depending on whether the bicycle is being ridden or not being ridden. When the bicycle is not being ridden and the chain is positioned on the largest/larger chaining and on the smallest sprocket, the chain guide outer plate of the front derailleur may touch the chain.
 - The cuffs of your clothing may get dirty from the chain while riding.
 - Apply grease to the left and right adapters before installing them.
 - For smooth operation, use the specified outer casing and the bottom bracket cable guide.
 - This front derailleur is for triple front chainwheel use only. It cannot be used with the double front chainwheel, as the shifting points do not match.
 - When installing the top route type, choose a frame that has three outer casing holders as shown in the illustration at right.
 - Use an outer casing which still has some length to spare even when the handlebars are turned all the way to both sides. Furthermore, check that the shifting lever does not touch the bicycle frame when the handlebars are turned all the way.
 - A special grease is used for the gear shifting cable. Do not use DURA-ACE grease or other types of grease, otherwise they may cause deterioration in gear shifting performance.
 - Grease the inner cable and the inside of the outer casing before use to ensure that they slide properly.
 - Operation of the levers related to gear shifting should be made only when the front chainwheel is turning.
 - If the brake fluid used in the oil disc brakes is of a type which tends to adhere to the plastic parts of the shifting lever, this may cause the plastic parts to crack or become discolored. Therefore, you should make sure that the brake fluid does not adhere to these plastic parts. The mineral oil which is used in SHIMANO disc brakes does not cause cracking or discoloration if it adheres to plastic parts, but such parts should be cleaned with alcohol beforehand to prevent foreign particles from adhering.
 - Do not disassemble the indicator and shifting lever unit, as this may damage them or cause mis-operation.
 - Parts are not guaranteed against natural wear or deterioration resulting from normal use.
 - For maximum performance we highly recommend Shimano lubricants and maintenance products
 - For any questions regarding methods of installation, adjustment, maintenance or operation, please contact a professional bicycle dealer.

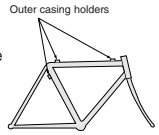
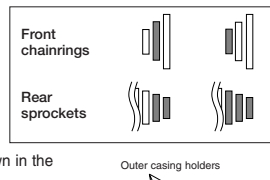

Technical Service Instructions

SI-5KA0A-002

Front Drive System

In order to realize the best performance, we recommend that the following combination be used.

Series	XT
Rapidfire (Shifting lever)	SL-M770
Outer casing	OT-SP41 (SIS-SP41)
Front derailleur	FD-M770-10 / FD-M771-10 / FD-M770-10E / FD-M771-10D
Front chainwheel	FC-M770-10
Chain	CN-HG94
Bottom bracket cable guide	SM-SP17 / SM-BT17

SHIMANO

SHIMANO AMERICAN CORPORATION
One Holland, Irvine, California 92618, U.S.A. Phone: +1-949-951-5003

SHIMANO EUROPE B.V.
Industrieweg 24, 8071 CT Nunspeet, The Netherlands Phone: +31-341-272222

SHIMANO INC.
3-77 Oimatsu-cho, Sakai-ku, Sakai-shi, Osaka 590-8577, Japan

* Service Instructions in further languages are available at : <http://techdocs.shimano.com>

Please note: specifications are subject to change for improvement without notice. (English)
© Jul. 2010 by Shimano Inc. XBC SZK Printed in Japan.

This service instruction explains how to use and maintain the Shimano bicycle parts which have been used on your new bicycle. For any questions regarding your bicycle or other matters which are not related to Shimano parts, please contact the place of purchase or the bicycle manufacturer.

Specifications

Front Derailleur	X = Available		
Model number	FD-M770-10E	FD-M770-10	FD-M771-10
Normal type		X	
Top route type		X	
Front chainwheel tooth difference		18T	
Min. difference between top and intermediate		10T	
Front derailleur installation band diameter	-	S, M, L	S, M, L
Chainstay angle (α)		66° - 69°	
Applicable chain line		50 mm	
Applicable front chainwheel		42T	

Installation band diameters:
S (28.6 mm), M (31.8 mm), L (34.9 mm)

When using the S, M size, use an installation band with a diameter of 28.6 mm, 31.8mm and install it to a L size adapter.

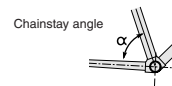

Chainwheel

Model number	FC-M770-10
Chainwheel tooth combination	42-32-24T
Bolt circle diameter	104 mm / 64 mm
Crank arm length	165 mm, 170 mm, 175 mm, 180 mm
Chain line	50 mm
Bottom bracket shell width	68, 73 mm
Thread dimensions	BC1.37 (68, 73mm)
Applicable bottom bracket	SM-BB70

Gear shifting operation

This release lever is equipped with a 2-way release mechanism which allows release operations to be carried out by either pushing or pulling the lever.

Both lever (A) and lever (B) always return to the initial position when they are released after shifting. When operating one of the levers, always be sure to turn the crank arm at the same time.

To shift from a small chaining to a larger chaining

When lever (A) is pressed once, there is a shift of one step from a small chaining to a larger chaining.

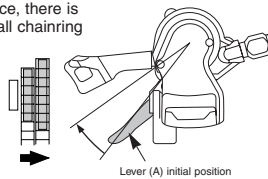

To shift from a large chaining to a smaller chaining

When lever (B) is pressed once, there is a shift of one step from a large chaining to a smaller chaining.

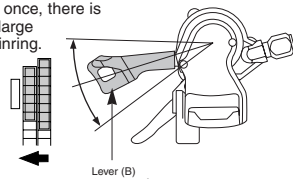

Example:
from intermediate chaining to largest chaining.

Example:
from largest chaining to intermediate chaining.

Installation of the Front Chainwheel and Front Derailleur

Follow the procedure in the figure.

- Use the special tool TL-FC32/36 to install the right adapter (counterclockwise thread) and the left adapter (clockwise thread).
Tightening torque: 35 - 50 N·m (305 - 435 in. lbs.)
Note : Spacers may be necessary depending on the bottom bracket shell width. For details, refer to "Spacer installation method".
- Insert the right crank unit.
- Set section A of the left crank into the axle of the right crank unit where the groove is wide.
- Use the TL-FC16/18 to tighten the cap.
Tightening torque: 0.7 - 1.5 N·m (6 - 13 in. lbs.)
- Push in the stopper plate and check that the plate pin is securely in place, and then tighten the bolt of the left crank arm. (5 mm Allen key)
Note : Each of the bolts should be evenly and equally tightened to 12 - 14 N·m (106 - 122 in. lbs.).

Spacer installation method

- Check whether the width of the bottom bracket shell is 68 mm or 73 mm.
- Next, install the adapter while referring to the illustrations below.

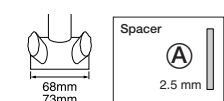

< FC-M770-10 >

Band Type	Bracket Type
68 mm	68 mm BB mount-type bracket
73 mm	73 mm

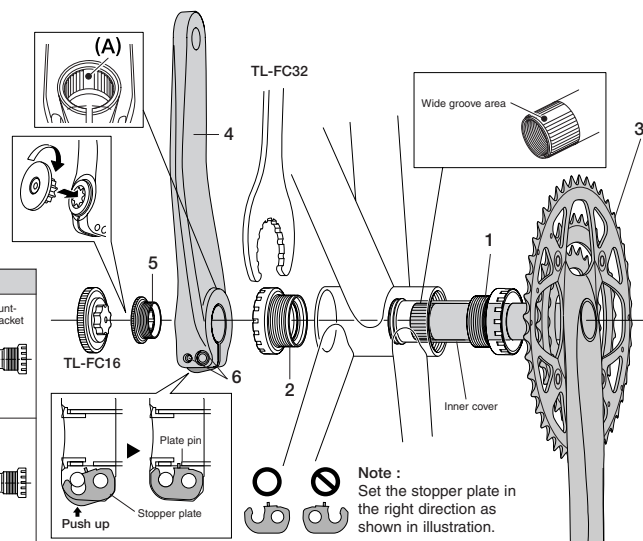

For bracket type

Install as shown in the illustration.

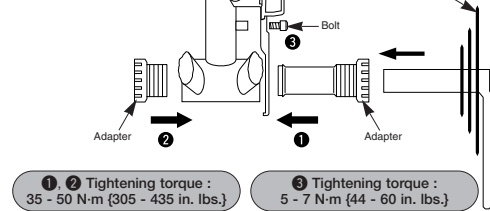

Adjust and then install the front derailleur as shown in the illustration. Do not remove the Pro-Set alignment block at this time.

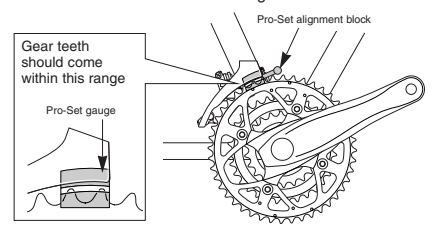

Note

When installing the components to carbon frame/handle bar surfaces, verify with the manufacturer of the carbon frame/parts for their recommendation on tightening torque in order to prevent over tightening that can cause damage to the carbon material and/or under tightening that can cause lack of fixing strength for the components.

The level section of the chain guide outer plate should be directly above and parallel to the largest chaining. Secure using a 5 mm Allen key.

Tightening torque :
5 - 7 N·m (44 - 60 in. lbs.)

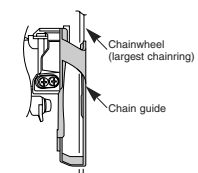

Chain length

Add 2 links (with the chain on both the largest sprocket and the largest chaining)

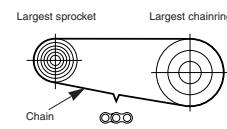

Installation of the lever

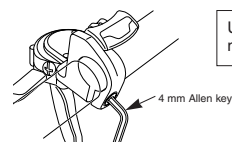

Use a handlebar grip with a maximum outer diameter of 36 mm.

Tightening torque :
5 N·m (44 in. lbs.)

If not using the indicator, this shifting lever can be installed either on the inside or the outside of the brake lever. If adjusting the position, remove the indicator, and then be sure to secure it in the new position with the two fixing bolts.

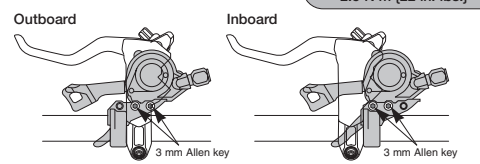

Tightening torque :
2.5 N·m (22 in. lbs.)

- Install the shifting lever in a position where it will not obstruct brake operation and gear shifting operation.
- Do not use in a combination which causes brake operation to be obstructed.

SIS Adjustment

Be sure to follow the sequence described below.

1. Low adjustment

First remove the Pro-Set alignment block. Next, set so that the clearance between the chain guide inner plate and the chain is 0 - 0.5 mm.

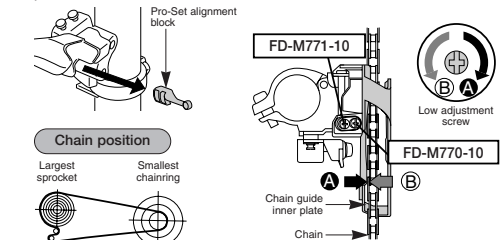

2. Connecting and securing the inner cable

Operate lever (B) two times or more, and check on the indicator that the lever is at the lowest position. Then remove the inner hole cover and connect the inner cable.

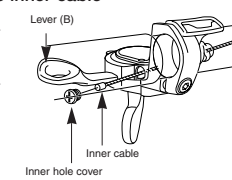

Install the inner hole cover by turning it as shown in the illustration until it stops. Do not turn it any further than this, otherwise it may damage the screw thread.

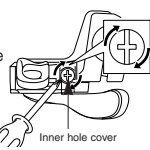

Cutting the outer casing

When cutting the outer casing, cut the opposite end to the end with the marking. After cutting the outer casing, make the end round so that the inside of the hole has a uniform diameter.



Attach the same outer end cap to the cut end of the outer casing.

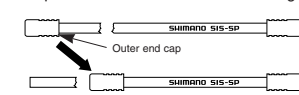

FD-M770-10

Use an 8 mm spanner or a 4 mm Allen key to tighten the wire fixing bolt.

< Normal type >

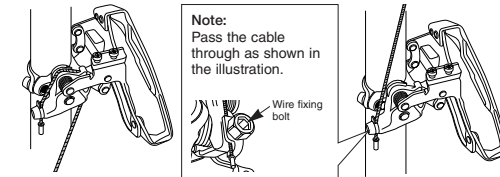

Note:
Pass the cable through as shown in the illustration.

< Top route type >

FD-M771-10

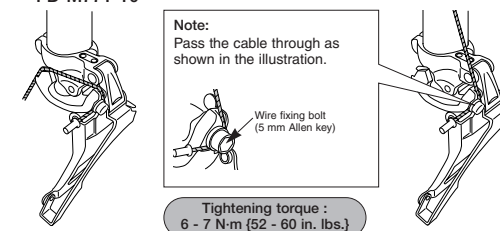

Note:
Pass the cable through as shown in the illustration.

Tightening torque :
6 - 7 N·m (52 - 60 in. lbs.)

After taking up the initial slack in the cable, re-secure to the front derailleur as shown in the illustration.

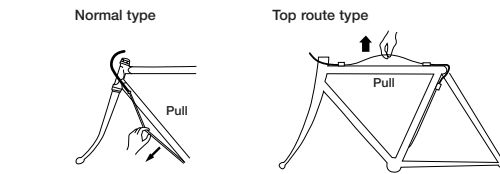

3. Top adjustment

Set so that the clearance between the chain guide outer plate and the chain is 0 - 0.5 mm.

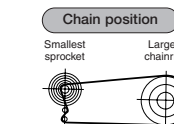

Chain position

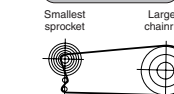

4. Adjustment of the intermediate chaining

When carrying out adjustment, set the chain to the largest sprocket, and at the front, set the chain to the intermediate chaining. Adjust using the outer casing adjustment barrel so that the clearance between the chain guide inner plate and the chain is 0 - 0.5 mm.

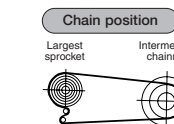

Chain position

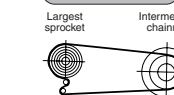

5. Troubleshooting chart

After completion of steps 1 - 4, move the shifting lever to check the shifting. (This also applies if shifting becomes difficult during use.)

If the chain falls to the crank side.	Tighten the top adjustment screw clockwise (about 1/4 turn).
If shifting is difficult from the intermediate chaining to the largest chaining.	Loosen the top adjustment screw counterclockwise (about 1/8 turn).
If shifting is difficult from the intermediate chaining to the smallest chaining.	Loosen the low adjustment screw counterclockwise (about 1/4 turn).
If there is interference between the chain and the front derailleur inner plate at the largest chaining.	Tighten the top adjustment screw clockwise (about 1/8 turn).
If there is interference between the chain and the front derailleur outer plate at the largest chaining.	Loosen the top adjustment screw counterclockwise (about 1/8 turn).
If the intermediate chaining is skipped when shifting from the largest chaining.	Loosen the outer casing adjustment barrel counterclockwise (1 or 2 turns).
If there is interference between the chain and front derailleur inner plate when the rear sprocket is shifted to the largest sprocket when the chainwheel is at the intermediate chaining position.	Tighten the outer casing adjustment barrel clockwise (1 or 2 turns).
If the chain falls to the bottom bracket side.	Tighten the low adjustment screw clockwise (about 1/2 turn).
If the lever is stiff when shifting from the intermediate chaining to the largest chaining	Loosen the top adjustment screw counterclockwise (about 1/4 turn).

Refer to the Service Instructions for the Rear Drive System for details on replacing and installing the indicator unit.