

## General Safety Information

### WARNING

- Before use, check the wheels to make sure that there are no bent or loose spokes, dents, scratches or cracks on the rim surface. Do not use the wheel if any of these problems are found.
- Do not use in combination with bottom link-type suspension forks. With these types of forks, the clearance between the hub axle and the brake shoes can change due to the operation of the suspension, so that when the brakes are applied, the brake shoes may touch the spokes.
- If the quick release mechanism is not used correctly, the wheel may come off the bicycle and serious injury could result. Read the Service Instructions for the quick release mechanism thoroughly before use.
- These wheels are designed for riding on paved surfaces. If the wheels are used on unpaved surfaces, the wheels may become bent or damaged, and accidents may result.
- Check that the wheels are fastened securely before riding the bicycle. If the wheels are loose in any way, they may come off the bicycle and serious injury may result.
- The hollow on the opposite side to the valve hole is an indicator for the amount of rim wear. If this hollow can no longer be seen, stop using the rim. If you continue using the rim, it may break, and the bicycle may fall over and an accident may result.
- Obtain and read the service instructions carefully prior to installing the parts.** Loose, worn or damaged parts may cause the bicycle to fall over and serious injury may occur as a result. We strongly recommend only using genuine Shimano replacement parts.
- Read these Technical Service Instructions carefully, and keep them in a safe place for later reference.

### CAUTION

- The tires should be inflated to the pressure indicated on the tires before use.
- Do not use rim tape. Rim tape may make it difficult to remove and install the tire, and the tire or tube may become damaged or the tires may suddenly puncture and come off, and severe injury may result.

### NOTICE

- The Shimano R55HC (high performance) brake shoes use an aggressive compound designed with an emphasis on maximum performance in wet conditions, however they will cause accelerated rim wear. Shimano accepts no responsibility for reduced rim life which might occur from using R55HC brake shoes.
- Use of genuine Shimano spokes, plugs and washers is strongly recommended. If non-Shimano parts are used, the area where the spokes fit into the hub unit may become damaged.
- Before use, check that there are no pieces of metal or other foreign objects sticking to the brake pads. If any such items are present, they may cause damage to the rim when the brakes are applied.
- We do not recommend that you use general-purpose alkaline puncture repair agents, as they may cause the rims to corrode and allow air leaks to occur.
- The plugs have large diameters and are easy to rotate in order to make it easier to increase the spoke tension. However, be careful not to overtighten the plugs when adjusting the spoke tensions. If the plugs are overtightened, damage to the rim may result. (We recommended that you ask authorized bicycle dealers to make the adjustments.)

#### Note:

- Use the rim-side plug to carry out truing and spoke tension adjustment for the WH-7900-C24-TL.
- If the wheel becomes stiff and difficult to turn, you should lubricate it with grease.
- Do not apply any oil to the inside of the hub, otherwise the grease will come out.
- Special spoke wrenches are available as optional accessories.
- We recommend that you ask authorized bicycle dealers to adjust the spoke tensions if there is any initial play in the spokes and after the first 1,000 km of riding.
- Spoke protectors (CP-WH23) are also sold separately. Please ask your bicycle dealer for details.
- For maximum performance we highly recommend Shimano lubricants and maintenance products.
- Reflectors (manufactured by CATEYE) are also sold separately. Please ask your bicycle dealer for details.

Model number	Specification	Color
RR-550-WUWSW	CPSC	White
RR-550-WUASW	AS	Amber
RR-317-WUASW	DIN	Amber

- Parts are not guaranteed against natural wear or deterioration resulting from normal use.

## Technical Service Instructions

SI-4GT0A-001

# WH-7900-C24-TL

Wheel

In order to realize the best performance, we recommend that the following combination be used.

Applicable tire size		Clincher tire / Tubeless tires
		700C (19C - 25C)
Chain	10-speed	CN-7901
Cassette sprocket	10-speed	CS-7900

























This wheel can be used with 8-gear, 9-gear and 10-gear sprocket sets. (If using a 10-gear sprocket set other than for a junior bicycle, use the accessory 1-mm spacer.) Refer to the Product Technical Information for details on combination with other parts such as chains and cassette sprockets.

### Specifications

Series	DURA-ACE	
Model number	WH-7900-C24-TL	
Speeds	8 / 9 / 10	
Rim size	700C (622 × 15C)	
Rim width	20.8 mm	

### Cassette sprocket

Sprockets marked by  are secured.

Model No.	CS-7900		
	11T - 21T	11T, 12T, 13T, 14T, 15T, 16T,  17T,  18T,  19T, 21T	
	11T - 23T	11T, 12T, 13T, 14T, 15T, 16T,  17T,  19T,  21T, 23T	
	11T - 25T	11T, 12T, 13T, 14T, 15T,  17T,  19T,  21T, 23T, 25T	
Sprocket tooth configuration	11T - 27T	11T, 12T, 13T, 14T, 15T,  17T,  19T,  21T, 24T, 27T	
	11T - 28T	11T, 12T, 13T, 14T, 15T,  17T,  19T,  21T, 24T, 28T	
	12T - 23T	12T, 13T, 14T, 15T, 16T,  17T,  18T,  19T, 21T, 23T	
	12T - 25T	12T, 13T, 14T, 15T, 16T,  17T,  19T,  21T, 23T, 25T	
	12T - 27T	12T, 13T, 14T, 15T, 16T,  17T,  19T,  21T, 24T, 27T	

### Replacing the spokes

- Pass the washer and plug over the spoke.
- After inserting the spoke into the hole in the hub flange, tighten the nut. When installing, use the spoke stopper to secure the spoke so that it does not turn, and then insert a screwdriver or similar tool into the groove in the nut to screw in the nut.
- Turn the plug clockwise to screw it into the screw hole in the rim. At this time, use the spoke stopper to stop the spoke from turning.

#### Note:

- If the washer is not installed, it will not be possible to adjust the spoke tension, so be sure to include the washer.
- Tighten the nut as far as the edges of the thread.

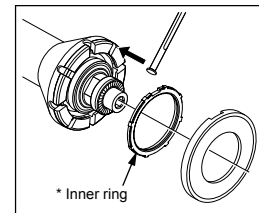

\* Inner ring

At the front, fit the heads of the spokes securely into the slots in the hub unit, otherwise damage may occur.

\* Install the inner ring so that it is fully set inside the tabs of the hub unit.

### Replacement of the freewheel body

- First, pull out the hub axle by following the procedure shown in the illustration. Disassembly from the freewheel side is not possible.

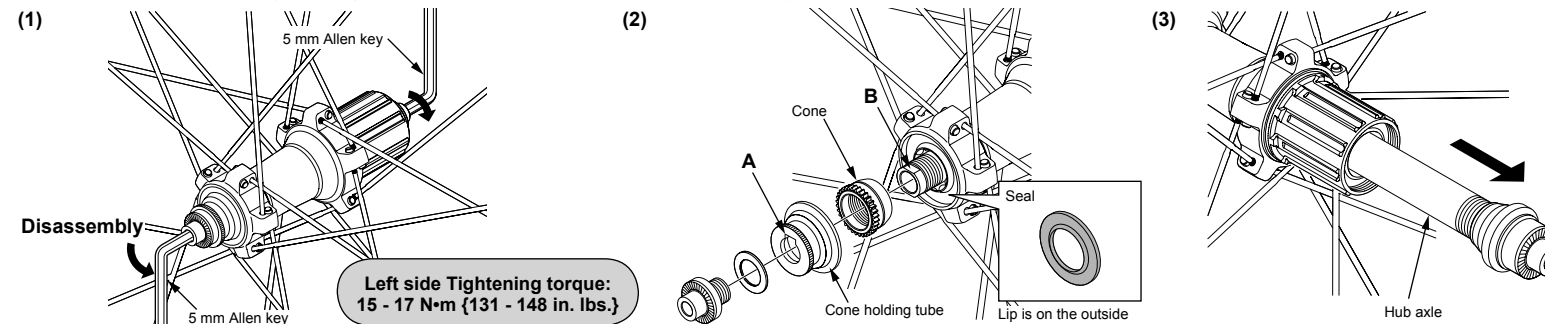

#### Note:

- When removing and installing the seal, do it very carefully so that the seal does not become bent. When reinstalling the seal, make sure that it is facing the right way, and insert it as far as it will go.
- Tighten the cone onto the hub axle until it has no looseness. While aligning the knurls of the cone and the knurls of the cone holding tube, align section A of the cone holding tube with section B on the hub axle.

- After removing the hub axle, remove the freewheel body fixing bolt (inside the freewheel body), and then replace the freewheel body.

#### Note:

When replacing the freewheel body, replace the freewheel body fixing bolt at the same time. Be sure to apply grease to the thread of the freewheel body fixing bolt, otherwise looseness or sticking may occur. Do not disassemble the freewheel or apply oil or grease to it, otherwise problems with operation may occur.

### Spoke lacing

Lace the spokes as shown in the illustration.

#### (For front)

At the front, a radial assembly is used at both the left and right

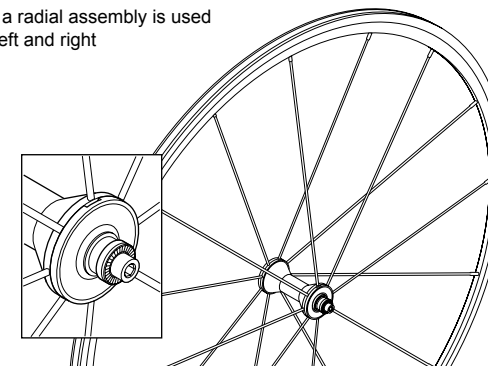

#### (For rear)

At the rear, a tangent assembly is used at both the left and right.

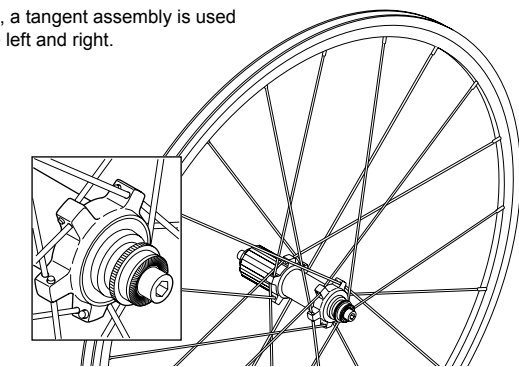

#### Spoke tension value

For front	For rear	
	Right (sprocket) side	Left side
1000 - 1400 N (225 - 315 lbf)	1200 - 1500 N (270 - 338 lbf)	600 - 900 N (135 - 203 lbf)

\* These values should be used as a guide only.

### Installation of the HG sprockets

For each sprocket, the surface that has the group mark should face outward and be positioned so that the wide parts of the gear projections on each sprocket and the A part (where the groove width is wide) of the freewheel body are aligned.

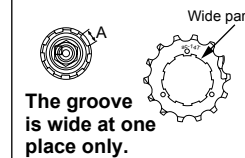

The groove is wide at one place only.

When installing the CS-7900 (10-gears) freewheel, install a spacer in the position shown in the illustration.

#### 11T - 21T, 11T - 23T

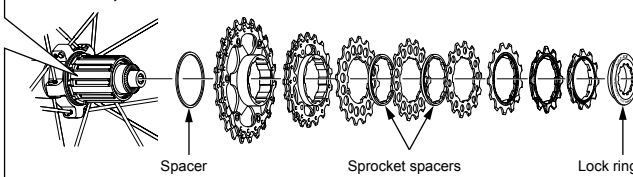

#### 11T - 25T, 11T - 27T, 11T - 28T

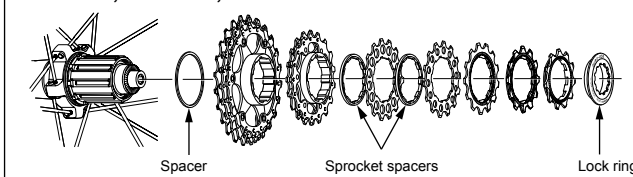

#### 12T - 23T, 12T - 25T, 12T - 27T

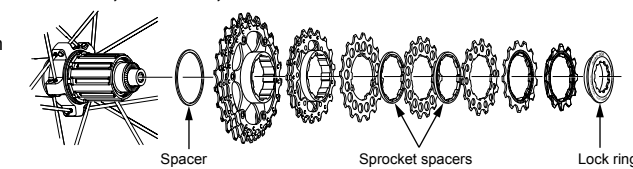

For installation of the HG sprockets, use the special tool (TL-LR15) to tighten the lock ring.

**Tightening torque:**  
30 - 50 N·m  
{261 - 435 in. lbs.}

To replace the HG sprockets, use the special tool (TL-LR15) and TL-SR21 to remove the lock ring.

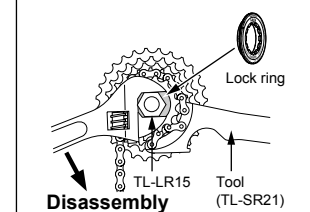

**Disassembly**

Tool (TL-SR21)

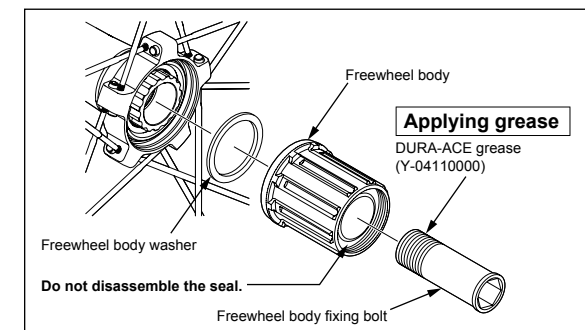

#### Applying grease

DURA-ACE grease  
(Y-04110000)

Do not disassemble the seal.

These service instructions explain how to use and maintain the Shimano bicycle parts which have been used on your new bicycle. For any questions regarding your bicycle or other matters which are not related to Shimano parts, please contact the place of purchase or the bicycle manufacturer.

\* Service Instructions in further languages are available at:  
<http://techdocs.shimano.com>

Please note: specifications are subject to change for improvement without notice. (English)

## SHIMANO

SHIMANO AMERICAN CORPORATION  
One Holland, Irvine, California 92618, U.S.A. Phone: +1-949-951-5003

SHIMANO EUROPE B.V.

SHIMANO INC.  
Industrieweg 24, 8071 CT Nunspeet, The Netherlands Phone: +31-341-272222 3-77 Omatsu-cho, Sakai-shi, Osaka 590-8577, Japan

© Jun. 2010 by Shimano Inc. AWS. SZK Printed in Malaysia.