



www.truvativ.com

5-Arm Cranksets and Chainrings

Congratulations!

Thank you for purchasing a Truvativ crankset. The following instructions should be read thoroughly before installation. Improper installation of your Truvativ crankset may cause an unexpected failure of the parts that could cause you to lose control of your bicycle resulting in serious injury or death. We recommend having your parts installed by a qualified bicycle technician. Truvativ assumes no responsibility for malfunction or injury due to faulty installation.

Application Chart

Part	Road	XC	AM	DH
Iso Flow Road, Touro, Elita				
Racing XR, Racing Team, Racing Jr.*				

Key: XC = Crosscountry
AM = All-Mountain/BMX Racing
DH = Downhill/Dirt Jumping/Street Riding

* Racing Jr. crank is for juvenile use only

Chainring, Crankbolt, and Bottom Bracket Compatibility

The following Truvativ road chainring combinations were designed to work together:

Chainring	Bottom Bracket
+38/46 or 48	cyclocross
+39/48 or 53	cyclocross or road double
+36/50	road double (110 bcd)
+42/52 or 55	road double
+30/42/52	road triple
+30/39/53	road triple
+48 or 52	track

Pairing the wrong chainrings together can result in poor shifting and performance. All Truvativ chainrings were designed to work with 8-, 9- and 10-speed drivetrains. For best shifting performance, use a 9- or 10-speed chain.

The 42T chainring designated for use in a triple chainring setup has shifting pins, the double version does not have shifting pins and is not suited for a triple chainring setup.

M15 and M12 crankbolts are compatible with any ISIS Drive certified bottom bracket with the corresponding sized threaded hole. M15 is typically used for crosscountry and road bike bottom brackets while M12 is typically used on downhill/All-mountain/BMX or titanium bottom brackets. ISIS Drive cranksets must be used with a certified ISIS Drive bottom bracket.

The M8 crankbolt is for use on all square taper and Power Spline bottom brackets. Square taper interface cranksets must be used with a Truvativ XR or LE Square bottom bracket. Power Spline cranksets must be used with a Truvativ Power Spline bottom bracket.

Crankarm Model	Interface	Spindle Width			Recommended Bottom Bracket Model
		108	113	118	
Racing Jr.	Square	42.5			Square XTRLE
IsoFlow Road SS		43.5			Square XTRLE
IsoFlow Road Dbl		45.5			Square XTRLE
IsoFlow Road Trip		43.5	46.5		Square XTRLE
Touro SS and Track		43.5			Square XTRLE
Touro Double		45.5			Square XTRLE
Touro Triple			46.5		Square XTRLE
Racing Jr.			42.5		Power Spline
IsoFlow Road SS			42.5		Power Spline
IsoFlow Road Dbl			44.5		Power Spline
IsoFlow Road Trip	Power Spline		46.5		Power Spline
Touro SS and Track		42.5			Power Spline
Touro Double			44.5		Power Spline
Touro Triple			46.5		Power Spline
Racing XR			42.5		ISIS Drive BMX (68mm shell only), Overdrive DH
Racing Team			42.5		ISIS Drive BMX (68mm shell only), Overdrive DH
Elita SS and Track		ISIS Drive	42.5		Giga Pipe SLLT, Team SL, Team Ti, Max Ti, Overdrive SL
Elita TT (42-55)			47		Giga Pipe SLLT, Team SL, Team Ti, Max Ti, Overdrive SL
Elita Double			44.5		Giga Pipe SLLT, Team SL, Team Ti, Max Ti, Overdrive SL
Elita Triple				46.5	Giga Pipe SLLT, Team SL, Team Ti, Max Ti, Overdrive SL
			46.5	Giga Pipe SLLT, Team SL, Team Ti, Max Ti, Overdrive SL	

Rev 2 May 20, 2004

Parts and Tools

Parts:



Road Chainrings:

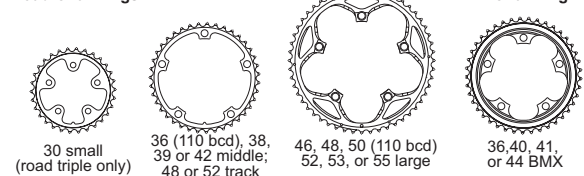

BMX Chainring:



Crankbolt assemblies:

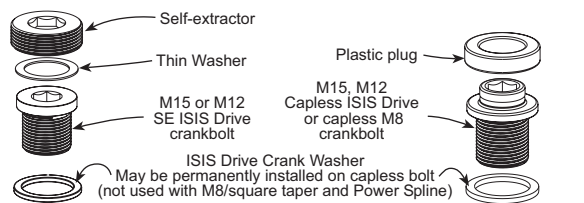

Chainring bolts and spacers:

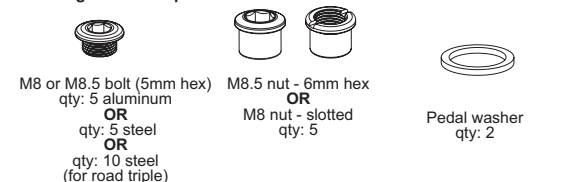

Miscellaneous:



Tools:

- 5mm, 8mm, hex key, 10mm hex key (for self extractor crankbolts, if applicable)
- Chainring nut spanner Park Tool™ CNW-1 or equivalent for slotted chainring nuts or 6mm hex key for hex chainring nuts
- Torque wrench

Supplies:

- Grease or titanium anti-seize for titanium bottom brackets

Parts Preparation

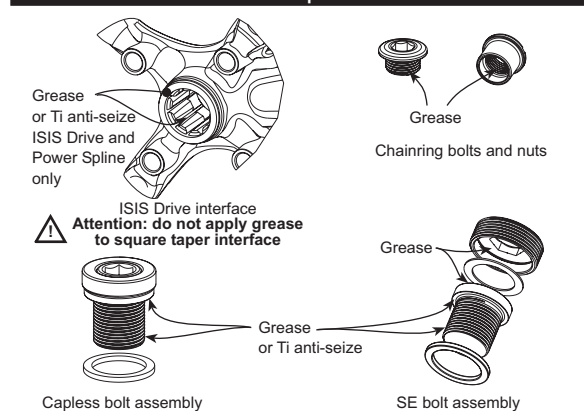

Assembly

Step 1

Aluminum bolts torque to: 8-9 N•m (5.9-6.6 ft•lbf, 82-92 kgf•cm)
Steel bolts torque to: 12-14 N•m (8.9-10.3 ft•lbf, 122-143 kgf•cm)

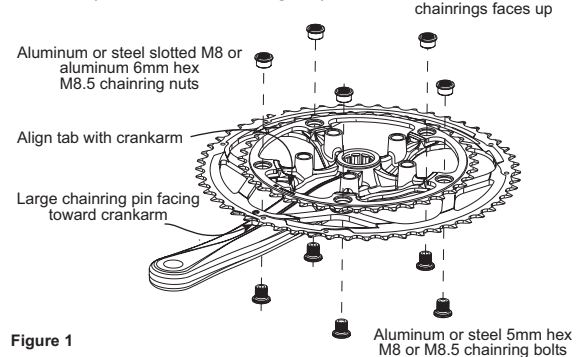

Figure 1

Road cranksets: Using a 5mm hex wrench and a chainring nut spanner or 6mm hex wrench, depending on the chainring nuts that were included with your crankset, assemble the large chainring, middle chainring, and prepared chainring nuts and bolts as shown in Figure 1. Make sure the large pin on the large chainring and the alignment tab on the middle ring are oriented in line with the crankarm as shown in Figure 1.

Track and BMX cranksets: Using a 5mm hex wrench and a chainring nut spanner or 6mm hex wrench, depending on the chainring nuts that were included with your crankset, assemble the single BMX or track chainring. Five-arm BMX cranksets and track cranksets have only one chainring that ONLY fits in the position of the middle chainring shown in Figure 1. A chainring can NOT be assembled in the large chainring position on a BMX or track crankset.

All cranksets: Use a torque wrench to tighten the bolts to 8-9 N•m (5.9-6.6 ft•lbf, 82-92 kgf•cm) for aluminum nuts and bolts, 12-14 N•m (8.9-10.3 ft•lbf, 122-143 kgf•cm) for steel nuts and bolts.

Step 2 (road triple cranksets only)

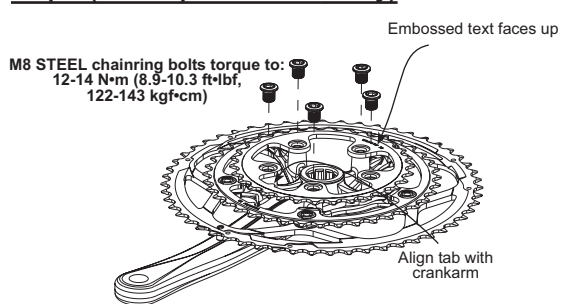

Figure 2

Mount the small chainring as shown in Figure 2 with the only alignment tab in line with the crankarm. Install STEEL chainring bolts with 5mm hex wrench and torque to 12-14 N•m (8.9-10.3 ft•lbf, 122-143 kgf•cm) using a torque wrench.

Step 3

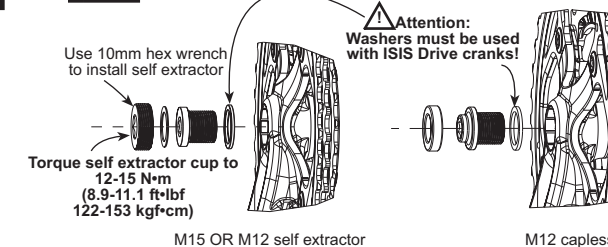

Figure 3

If the crankbolts have not been assembled yet, assemble them as shown in Figure 3. ISIS Drive cranks MUST use the crank washer or damage will result when the cranks are installed. Note that the crank washer may be manufactured so that it is permanently installed on the crankbolt. M8 crankbolts used with square taper and Power Spline cranks do not use a crank washer.

Step 4

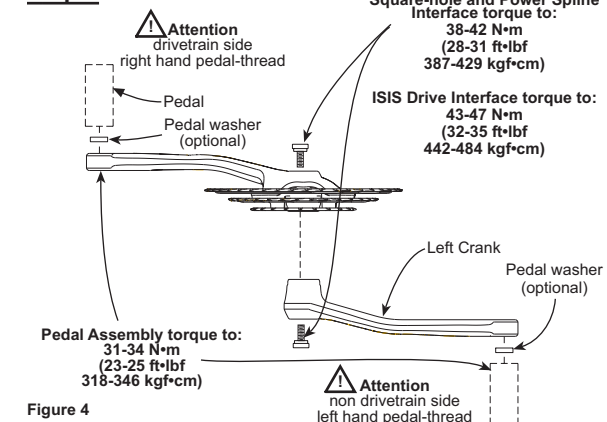

Figure 4

Apply grease to ISIS Drive and Power Spline bottom bracket splines, for square taper make sure the tapers are clean and free of grease. Assemble the crankarms to the bottom bracket using an 8mm hex wrench. Grease the pedal threads and assemble the pedals to the crankarms, and torque all bolts as shown in Figure 4.

Warranty

We at Truvativ stand behind our products and our customers. Our Racing Team cranksets are warranted for 2 years from the date of purchase against manufacturing defects and workmanship. All other cranksets are warranted for 1 year from the date of purchase against manufacturing defects and workmanship. This warranty is not valid for "abused" or neglected products, or products that are damaged by improper installation or assembly. We define an abused product as one that was subjected to use outside of its design intent. Please pay special attention to the Application Chart shown earlier in this manual to verify you are using the product for its intended purpose.

If you feel you have a warranty claim, would like to learn more about our warranty policy, or have further questions or comments please visit our web site at www.truvativ.com. You may also contact us using the information below:

Truvativ USA
Tel [1] (805) 787-0917
amsales@truvativ.com
warranty@truvativ.com

Truvativ Germany
Tel [49] 23 02 399-280
eusales@truvativ.com

Truvativ Asia (Taiwan)
Tel [886] (42) 496 5899
taiwansales@truvativ.com